

L= 31.13'
 R= 60.0'
 $\Delta = 29^\circ 43' 31''$
 CL= 30.78'
 CB= N89° 24' 02" W

L= 154.95'
 R= 330.0'
 $\Delta = 26^\circ 54' 13''$
 CL= 153.53'
 CB= S58° 37' 47" W

TREE TABLE		
NO.	SIZE	TYPE
501	6'	OAK
502	1.0'	OAK
503	5.7'	OAK
504	4.5'	OAK
505	7.0'	OAK
506	8.0'	OAK
507	4.0'	ELM
508	3.5'	OAK
509	4.3'	OAK
510	6.0'	OAK

1. VERIFY JOINT LAYOUT FOR SIDEWALKS WITH CONTRACTOR PRIOR TO CONSTRUCTION.
2. ALL SITE WORK, INCLUDING LOCATION OF TRASH DUMPSTER, TEMPORARY TOILET FACILITIES, TEMPORARY CONSTRUCTION BARCADE/FENCING CONSTRUCTION TRAILER, CLEARING PROCEDURE GRADING AND DRAINAGE, CONFORMANCE TO POLLUTION AND PREVENTION CONTROL, AND TEMPORARY UTILITY FACILITIES, ETC. SHALL BE IN ACCORDANCE WITH THE CITY AS WELL AS SUBDIVISION PROPERTY OWNERS ASSOCIATION GUIDELINES.
3. BUILDER AND OWNER SHALL BE RESPONSIBLE FOR ALL TEMPORARY UTILITIES TO THE CONSTRUCTION SITE.
4. CONTRACTOR SHALL BE RESPONSIBLE FOR FINAL GRADING ONLY. OWNER SHALL PROVIDE ALL LANDSCAPING, SOD, AND IRRIGATION SYSTEM.

LEGAL DESCRIPTION

LOT	160
UNIT	3
SUBDIVISION	CASCADE AT CANYON LAKE
COUNTY	COMAL COUNTY, TX
ADDRESS	118 CARTAMA

NORTH ARROW

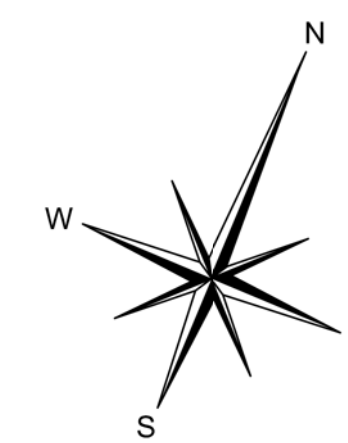

1 SITE PLAN
 SCALE: 1"=20'-0"

PRICING SET

DISTINCTIVE DRAFTING & DESIGN HEREBY RESERVES ITS COMMON COPYRIGHT LAW & OTHER PROPERTY RIGHTS IN THESE PLANS & DESIGNS. THESE PLANS ARE NOT TO BE REPRODUCED, CHANGED OR COPIED IN ANY FORM OR MANNER WHATSOEVER, NOR ARE THEY TO BE ASSIGNED TO ANY THIRD PARTY, WITHOUT FIRST OBTAINING THE EXPRESS WRITTEN PERMISSION FROM DISTINCTIVE DRAFTING & DESIGN. DISTINCTIVE DRAFTING & DESIGN TAKES NO RESPONSIBILITY FOR THE CONSTRUCTION OF THE RESIDENCE OR BUILDING.

DATE: 1/27/2022
 DRAWN BY:
 DISTINCTIVE
 PLAN # - 13-21

Lot 160, Cascada at Canyon Lake Unit 3, Comal County 118 Cartama

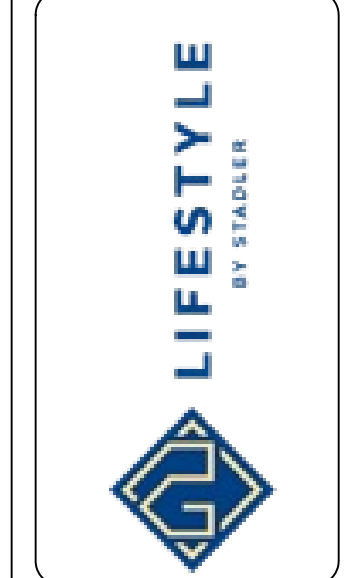

2312 S. EXPRESSWAY 83 SUITE # B
 HARLINGEN, TX 78552
 OFFICE: (956) 425-7040
 8000 WEST I-10 SUITE #600
 SAN ANTONIO, TX 78230
 OFFICE: (210) 525-7985



SHEET NUMBER

2

© 2021

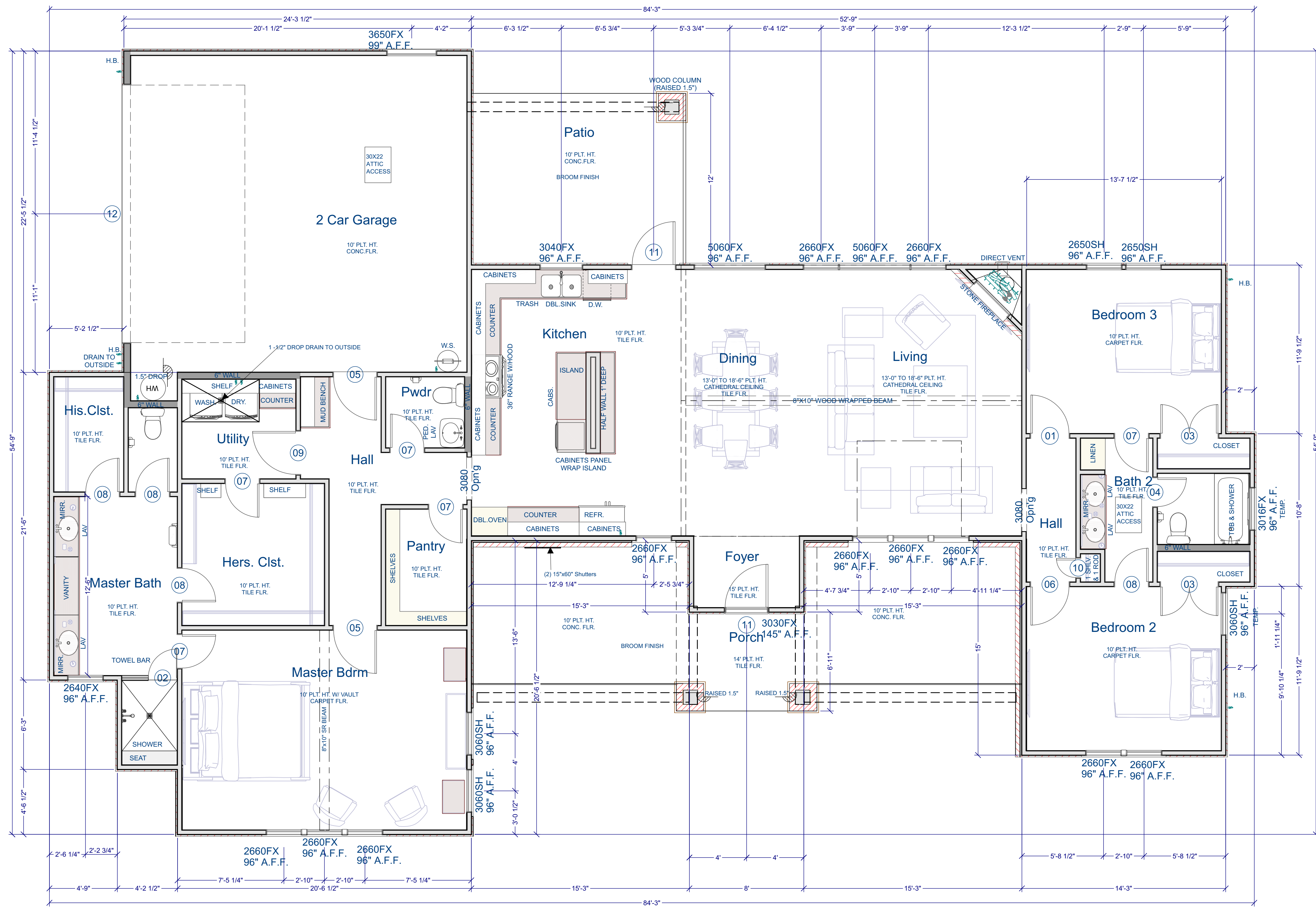

1 FLOOR PLAN
SCALE: 1/4"=1'-0"

DOOR SCHEDULE				
NUMBER	QTY	SIZE	TYPE	COMMENTS
01	1	2880 L IN	HINGED	
02	1	2050 R	SHOWER	GLASS DOOR
03	2	4080 L/R IN	DOUBLE HINGED	
04	1	2080 L IN	HINGED	
05	2	3080 L IN	HINGED	
06	1	2880 R IN	HINGED	
07	5	2480 L IN	HINGED	
08	4	2480 R IN	HINGED	
09	1	3080 R IN	HINGED	
10	1	1468 R IN	HINGED	
11	2	3080 R EX	HINGED	
12	1	18080	GARAGE	

WALL SCHEDULE	
2D SYMBOL	WALL TYPE(S)
[Symbol]	STUCCO-4/BRICK-4
[Symbol]	INTERIOR-4
[Symbol]	STUCCO-4
[Symbol]	INTERIOR-6
[Symbol]	STUCCO-6
[Symbol]	STUCCO-4/STUCCO-4

AREA TABULATION	
LIVING AREA	2,158.0'
2 CAR GARAGE	562.0'
CVD. PATIO	180.0'
CVD. PORCH	364.0'
TOTAL NON LIVING	1,106.0'
TOTAL AREA	3,264.0'
STONE LUG	27.0'

DATE: 1/27/2022
DRAWN BY:
DISTINCTIVE
PLAN # - 13-21

**Lot 160, Cascada at
Canyon Lake Unit 3,
Comal County
118 Cartama**



2312 S. EXPRESSWAY 83 SUITE # B
HARLINGEN, TX 78552
OFFICE: (956) 425-7040
8000 WEST I-10 SUITE #600
SAN ANTONIO, TX 78230
OFFICE: (210) 525-7985

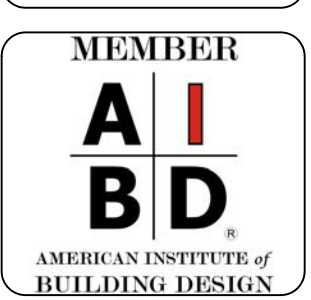

SHEET NUMBER

5

© 2021

PRICING SET

DISTINCTIVE DRAFTING & DESIGN HEREBY RESERVES ITS COMMON COPYRIGHT LAW & OTHER PROPERTY RIGHTS IN THESE PLANS & DESIGNS. THESE PLANS ARE NOT TO BE REPRODUCED, CHANGED OR COPIED IN ANY FORM OR MANNER WHATSOEVER, NOR ARE THEY TO BE ASSIGNED TO ANY THIRD PARTY, WITHOUT FIRST OBTAINING THE EXPRESS WRITTEN PERMISSION FROM DISTINCTIVE DRAFTING & DESIGN. DISTINCTIVE DRAFTING & DESIGN TAKES NO RESPONSIBILITY FOR THE CONSTRUCTION OF THE RESIDENCE OR BUILDING.

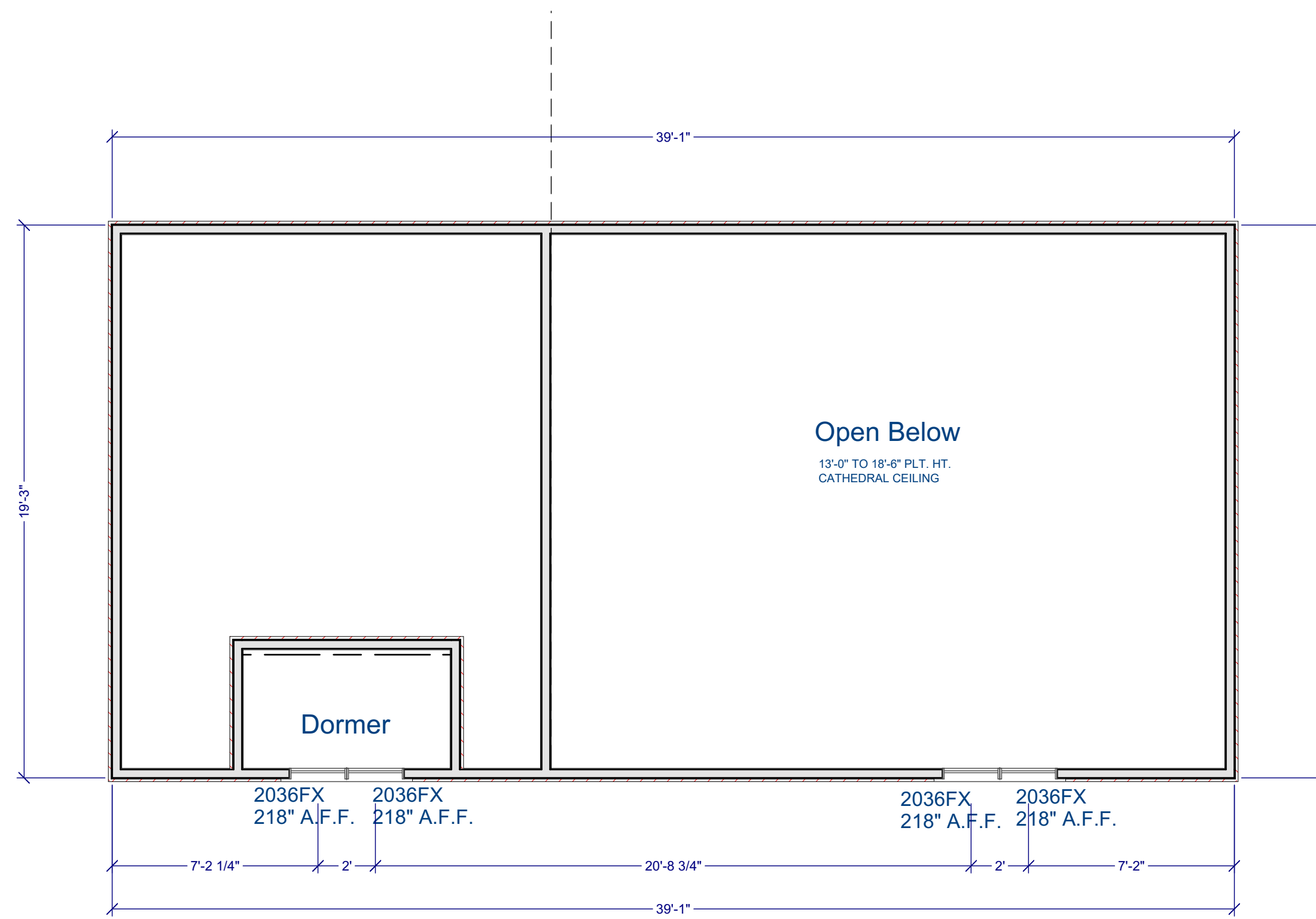

DOOR SCHEDULE				
NUMBER	QTY	SIZE	TYPE	COMMENTS
01	1	2880 L IN	HINGED	
02	1	2050 R	SHOWER	GLASS DOOR
03	2	4080 L/R IN	DOUBLE HINGED	
04	1	2080 L IN	HINGED	
05	2	3080 L IN	HINGED	
06	1	2880 R IN	HINGED	
07	5	2480 L IN	HINGED	
08	4	2480 R IN	HINGED	
09	1	3080 R IN	HINGED	
10	1	1468 R IN	HINGED	
11	2	3080 R EX	HINGED	
12	1	18080	GARAGE	

WALL SCHEDULE	
2D SYMBOL	WALL TYPE(S)
	STUCCO-4/BRICK-4
	INTERIOR-4
	STUCCO-4
	INTERIOR-6
	STUCCO-6
	STUCCO-4/STUCCO-4

AREA TABULATION

LIVING AREA	2,158.0'
2 CAR GARAGE	562.0'
CVD. PATIO	180.0'
CVD. PORCH	364.0'
TOTAL NON LIVING	1,106.0'
TOTAL AREA	3,264.0'
STONE LUG	27.0'

DISTINCTIVE DRAFTING & DESIGN HEREBY RESERVES ITS COMMON COPYRIGHT LAW & OTHER PROPERTY RIGHTS IN THESE PLANS & DESIGNS. THESE PLANS ARE NOT TO BE REPRODUCED, CHANGED OR COPIED IN ANY FORM OR MANNER WHATSOEVER, NOR ARE THEY TO BE ASSIGNED TO ANY THIRD PARTY, WITHOUT FIRST OBTAINING THE EXPRESS WRITTEN PERMISSION FROM DISTINCTIVE DRAFTING & DESIGN. DISTINCTIVE DRAFTING & DESIGN TAKES NO RESPONSIBILITY FOR THE CONSTRUCTION OF THE RESIDENCE OR BUILDING.

PRICING SET

DATE: 1/27/2022
DRAWN BY:
DISTINCTIVE
PLAN # - 13-21

**Lot 160, Cascada at
Canyon Lake Unit 3,
Comal County
118 Cartama**



2312 S. EXPRESSWAY 83 SUITE # B
HARLINGEN, TX 78552
OFFICE: (956) 425-7040
8000 WEST L-10 SUITE #600
SAN ANTONIO, TX 78230
OFFICE: (210) 525-7985

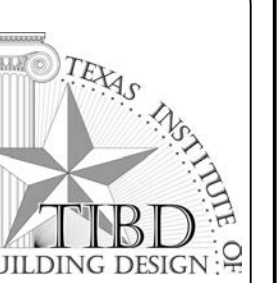

SHEET NUMBER

6

© 2021



1 FRONT ELEVATION
SCALE: 1/4"=1'-0"

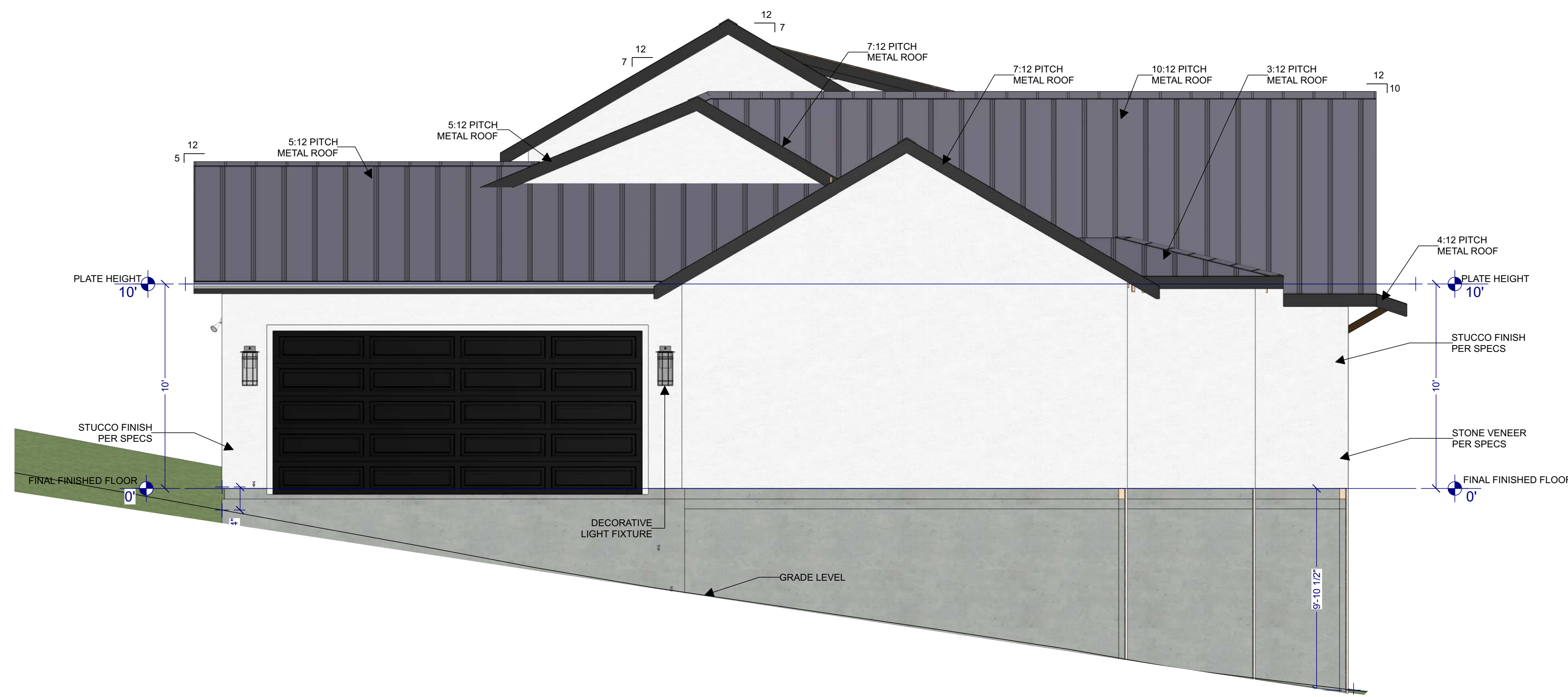

2 LEFT ELEVATION
SCALE: 1/4"=1'-0"

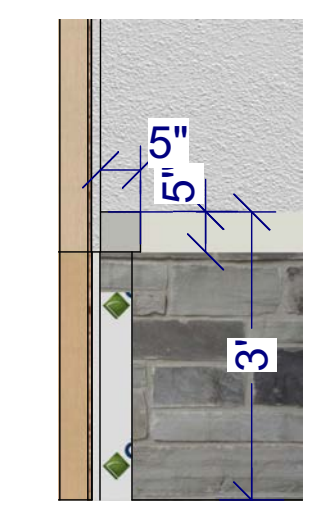

3 WAINSCOT DETAIL
SCALE: 1/2"=1'-0"

PRICING SET

DISTINCTIVE DRAFTING & DESIGN HEREBY RESERVES ITS COMMON COPYRIGHT LAW & OTHER PROPERTY RIGHTS IN THESE PLANS & DESIGNS. THESE PLANS ARE NOT TO BE REPRODUCED, CHANGED OR COPIED IN ANY FORM OR MANNER WHATSOEVER, NOR ARE THEY TO BE ASSIGNED TO ANY THIRD PARTY, WITHOUT FIRST OBTAINING THE EXPRESS WRITTEN PERMISSION FROM DISTINCTIVE DRAFTING & DESIGN. DISTINCTIVE DRAFTING & DESIGN TAKES NO RESPONSIBILITY FOR THE CONSTRUCTION OF THE RESIDENCE OR BUILDING.

DATE: 1/27/2022
DRAWN BY:
DISTINCTIVE
PLAN # - 13-21

**Lot 160, Cascada at
Canyon Lake Unit 3,
Comal County
118 Cartama**

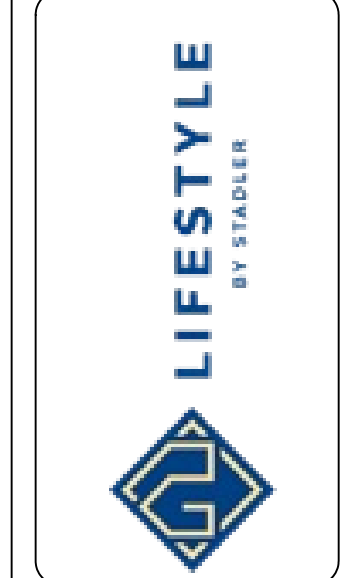

2312 S. EXPRESSWAY 83 SUITE # B
HARLINGEN, TX 78552
OFFICE: (956) 425-7040
8000 WEST I-10 SUITE #600
SAN ANTONIO, TX 78230
OFFICE: (210) 525-7985

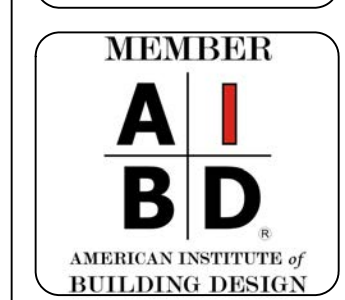

SHEET NUMBER

7

© 2021



1 REAR ELEVATION
SCALE: 1/4"=1'-0"

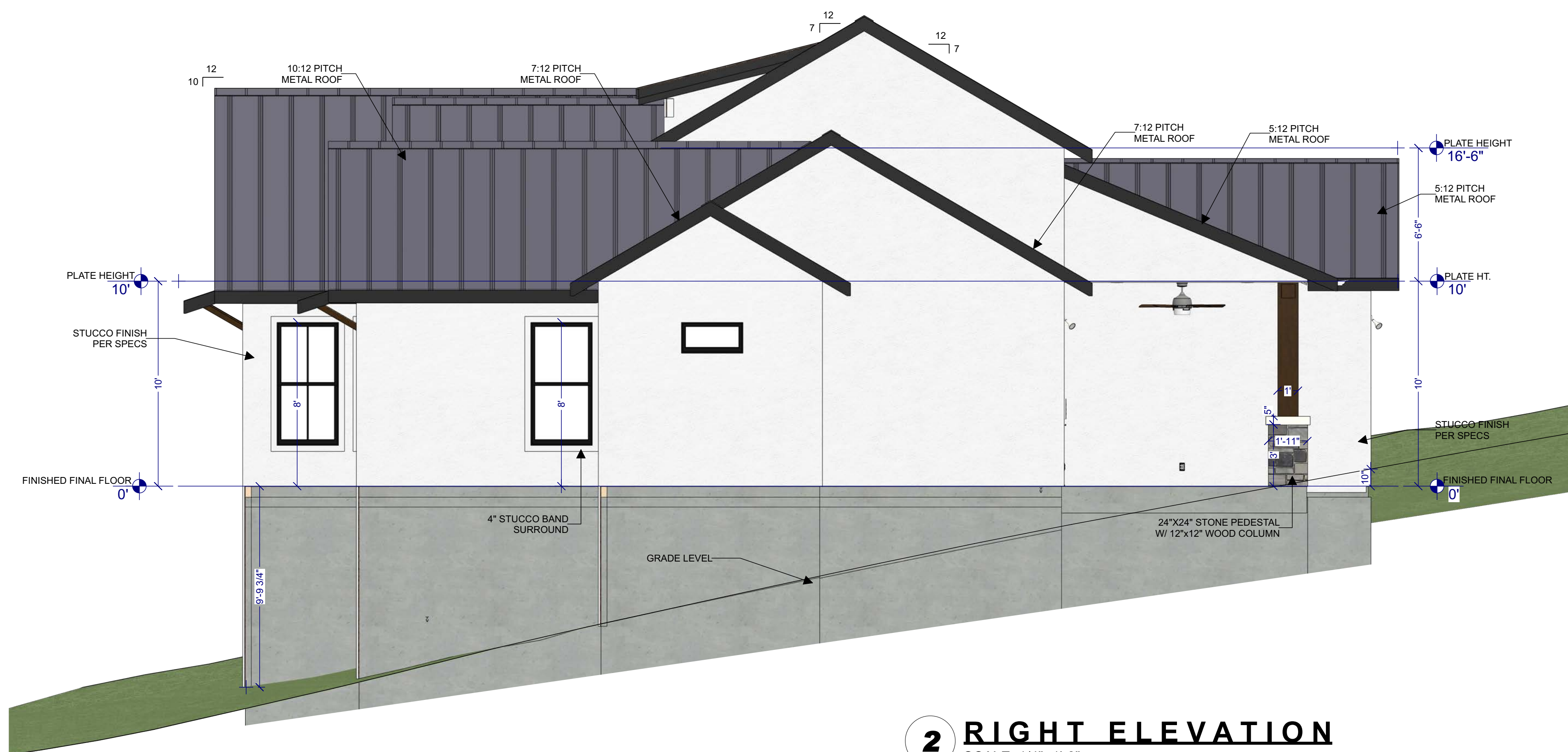

2 RIGHT ELEVATION
SCALE: 1/4"=1'-0"

PRICING SET

DISTINCTIVE DRAFTING & DESIGN HEREBY RESERVES ITS COMMON COPYRIGHT LAW & OTHER PROPERTY RIGHTS IN THESE PLANS & DESIGNS. THESE PLANS ARE NOT TO BE REPRODUCED, CHANGED OR COPIED IN ANY FORM OR MANNER WHATSOEVER, NOR ARE THEY TO BE ASSIGNED TO ANY THIRD PARTY, WITHOUT FIRST OBTAINING THE EXPRESS WRITTEN PERMISSION FROM DISTINCTIVE DRAFTING & DESIGN. DISTINCTIVE DRAFTING & DESIGN TAKES NO RESPONSIBILITY FOR THE CONSTRUCTION OF THE RESIDENCE OR BUILDING.

DATE: 1/27/2022
DRAWN BY:
DISTINCTIVE
PLAN # - 13-21

**Lot 160, Cascada at
Canyon Lake Unit 3,
Comal County
118 Cartama**



2312 S. EXPRESSWAY 83 SUITE # B
HARLINGEN, TX 78552
OFFICE: (956) 425-7040
8000 WEST I-10 SUITE #600
SAN ANTONIO, TX 78230
OFFICE: (210) 525-7985

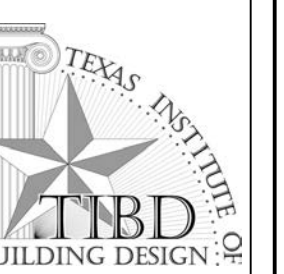

SHEET NUMBER

8

© 2021



2312 S. EXPRESSWAY 83 SUITE # B
 HARLINGEN, TX 78552
 OFFICE (956) 425-7040
 8000 WEST L-10 SUITE #600
 SAN ANTONIO, TX 78230
 OFFICE (210) 525-7985



SHEET NUMBER

9

© 2021

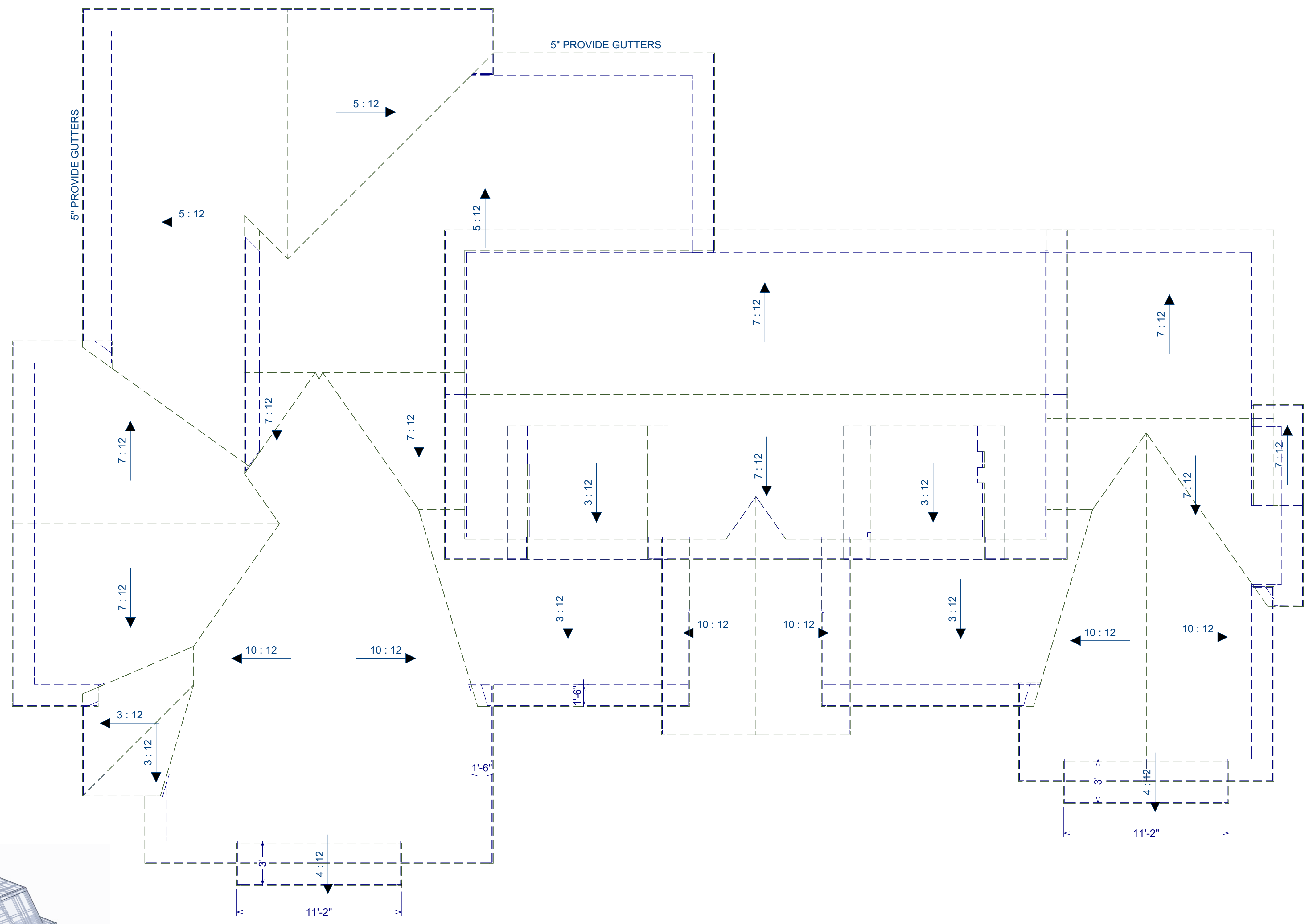

1 ROOF PLAN
 SCALE: 1/4"=1'-0"

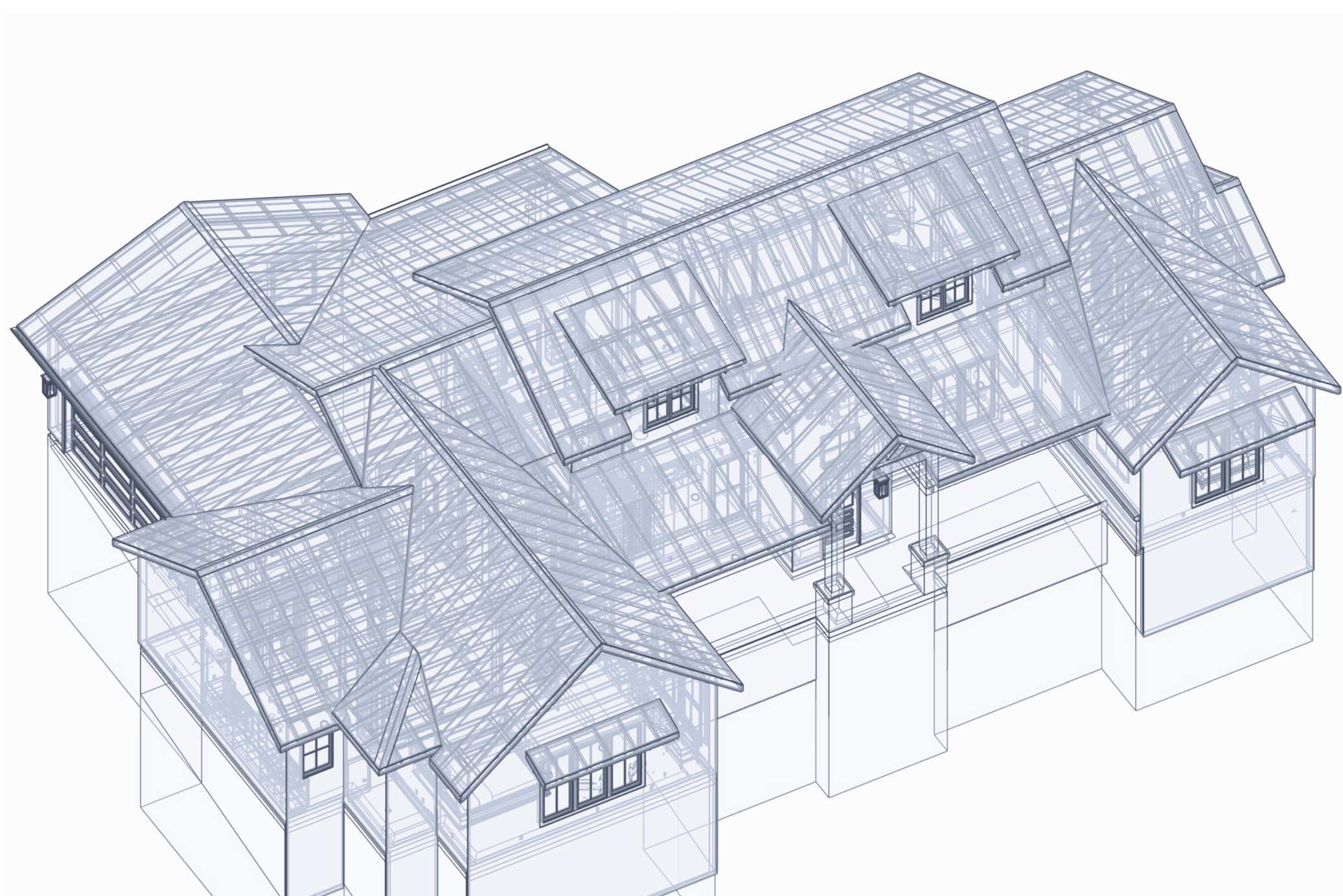

2 ROOF OVERVIEW
 SCALE: NOT TO SCALE

ROOF NOTES

- 01. METAL ROOF
- 02. 3:12, 4:12, 5:12, 7:12, 10:12 ROOF PITCH
- 03. 18" OVERHANG

DISTINCTIVE DRAFTING & DESIGN HEREBY RESERVES ITS COMMON COPYRIGHT LAW & OTHER PROPERTY RIGHTS IN THESE PLANS & DESIGNS. THESE PLANS ARE NOT TO BE REPRODUCED, CHANGED OR COPIED IN ANY FORM OR MANNER WHATSOEVER, NOR ARE THEY TO BE ASSIGNED TO ANY THIRD PARTY, WITHOUT FIRST OBTAINING THE EXPRESS WRITTEN PERMISSION FROM DISTINCTIVE DRAFTING & DESIGN. DISTINCTIVE DRAFTING & DESIGN TAKES NO RESPONSIBILITY FOR THE CONSTRUCTION OF THE RESIDENCE OR BUILDING.

PRICING SET

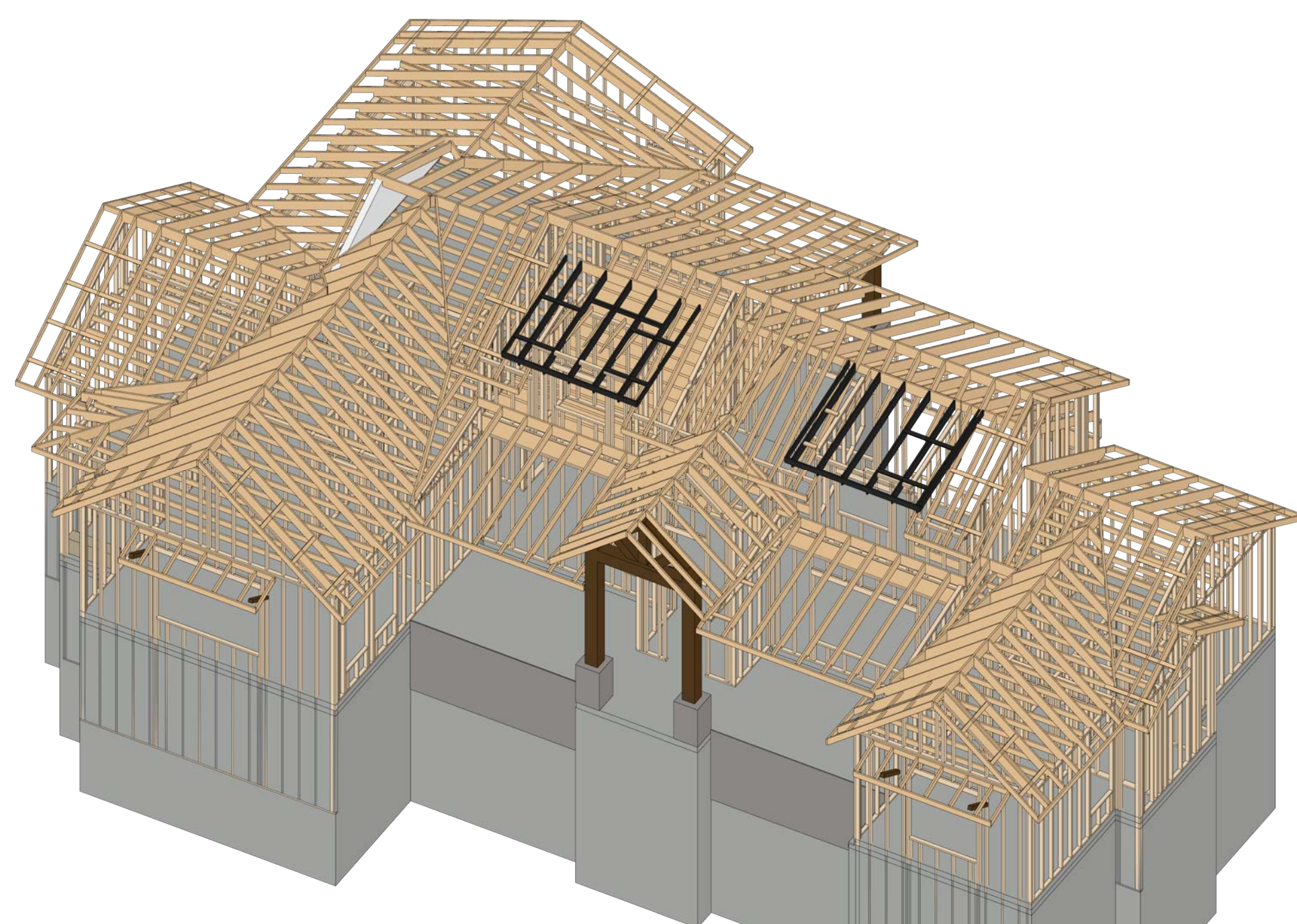

2 FRAMING OVERVIEW
SCALE: N.T.S.

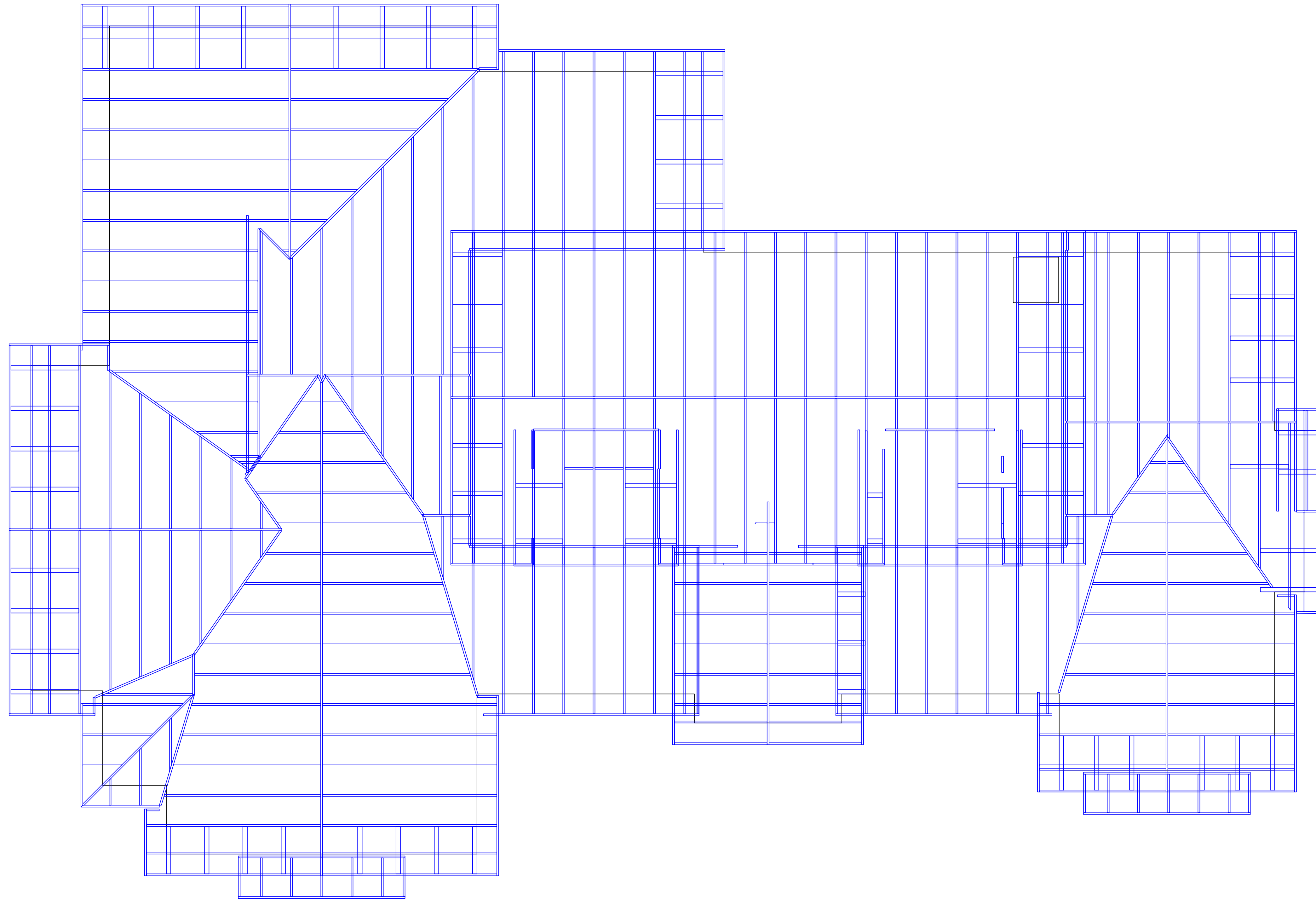

1 FRAMING PLAN
SCALE: 1/4"=1'-0"

NOTES
RAFTER DIAGRAM FOR
ILLUSTRATION PURPOSE
ONLY. PLEASE REFER TO
ENGINEER FRAME PLANS
FOR DETAILS

DISTINCTIVE DRAFTING & DESIGN HEREBY
RESERVES ITS COMMON COPYRIGHT LAW &
OTHER PROPERTY RIGHTS IN THESE PLANS &
DESIGNS. THESE PLANS ARE NOT TO BE
REPRODUCED, CHANGED OR COPIED IN ANY
FORM OR MANNER WHATSOEVER, NOR ARE
THEY TO BE ASSIGNED TO ANY THIRD PARTY,
WITHOUT FIRST OBTAINING THE EXPRESS
WRITTEN PERMISSION FROM DISTINCTIVE
DRAFTING & DESIGN. DISTINCTIVE DRAFTING &
DESIGN TAKES NO RESPONSIBILITY FOR THE
CONSTRUCTION OF THE RESIDENCE OR
BUILDING.

PRICING SET

DATE: 1/27/2022
DRAWN BY:
DISTINCTIVE
PLAN # - 13-21

**Lot 160, Cascada at
Canyon Lake Unit 3,
Comal County
118 Cartama**

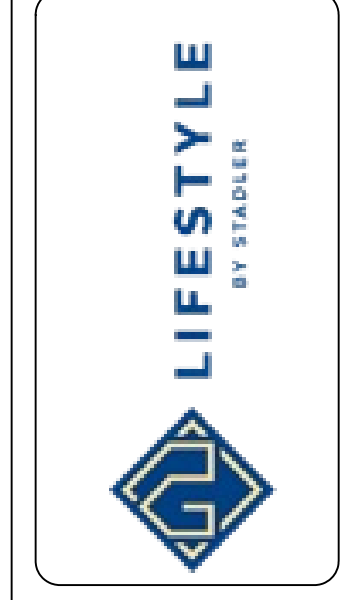

2312 S. EXPRESSWAY 83 SUITE # B
HARLINGEN, TX 78552
OFFICE: (956) 425-7040
8000 WEST I-10 SUITE #600
SAN ANTONIO, TX 78230
OFFICE: (210) 525-7985



SHEET NUMBER

10

© 2021

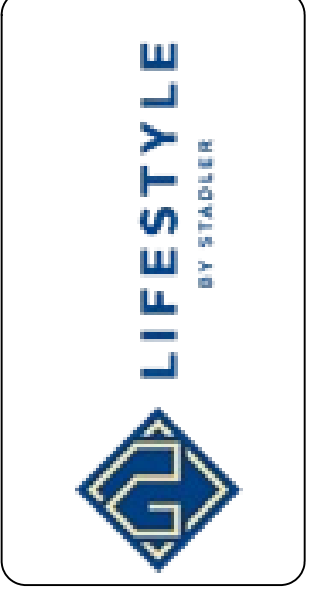

2312 S. EXPRESSWAY 83 SUITE # B
 HARLINGEN, TX 78552
 OFFICE: (956) 425-7040
 8000 WEST I-10 SUITE #600
 SAN ANTONIO, TX 78230
 OFFICE: (210) 525-7985



SHEET NUMBER

11

SYMBOL	DESCRIPTION	REMARKS
	EXTERIOR LANTERN 2	
	HEADINGLEY CEILING FAN	
	TELEVISION JACK	
	SPOTLIGHT 2	
	SMOKE DETECTOR 1	
	SAG HARBOR CHANDELIER 1	
	RYKER CHANDELIER LARGE	
	RECESSED DOWN LIGHT 6	
	ORLEANS PENDANT	
	GFCI WP	
	GFCI	
	DUPLEX, FLOOR MOUNTED	
	DUPLEX, CEILING MOUNTED	
	DUPLEX	
	DOORBELL	
	CRANE FLUSH DRUM LIGHT	
	CO/SMOKE DETECTOR	
	BOWL SCONCE 3	
	220V	
	THREE WAY	
	SINGLE POLE	
	2 GANG SWITCH	
	3 GANG SWITCH	
	PUSH BUTTON SWITCH	
	FOUR WAY	
	MEDIUM RECESSED TUBE LIGHT (48W60)	
	EXHAUST	

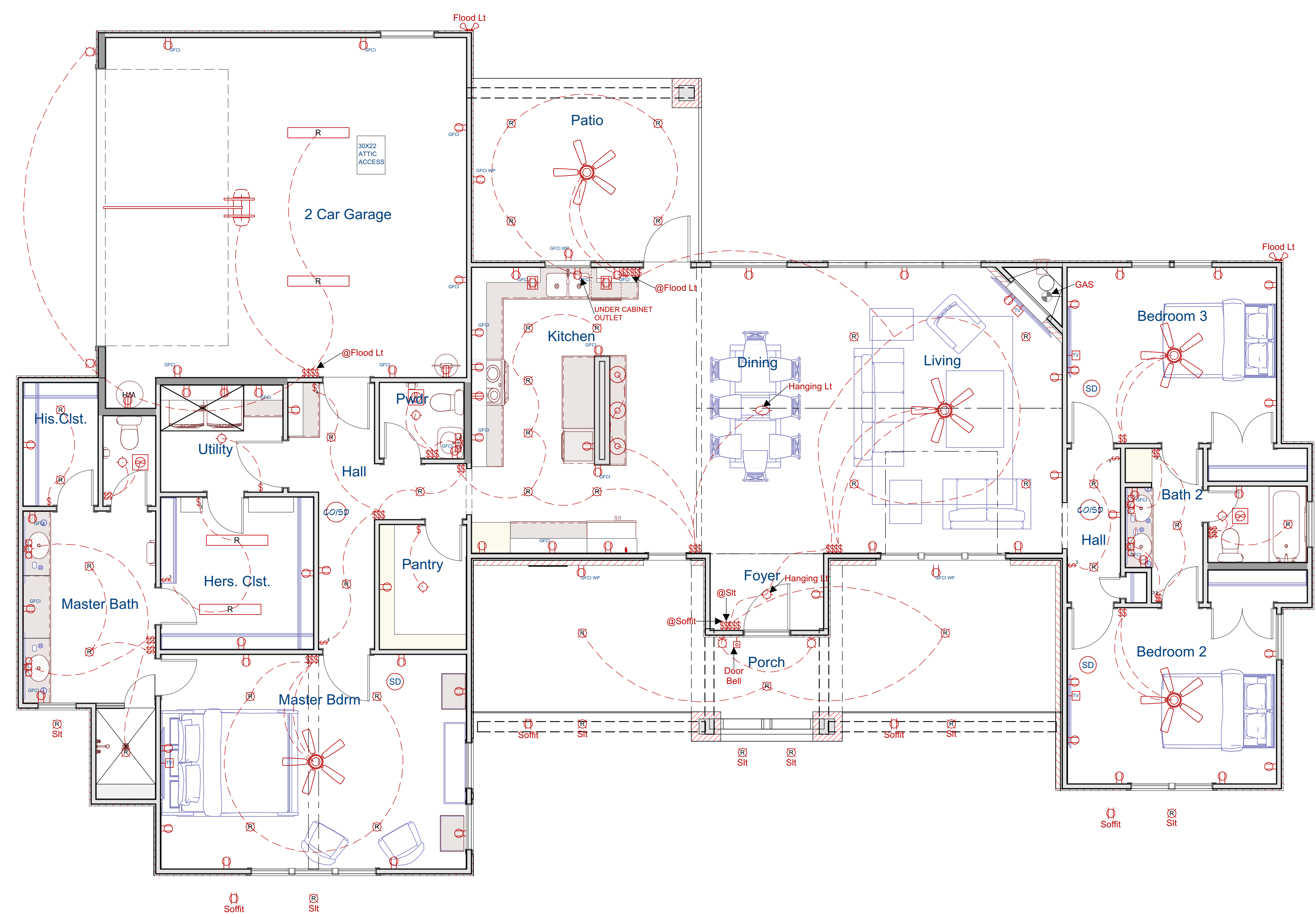

1 ELECTRICAL PLAN
 SCALE: 1/4"=1'-0"

PRICING SET

DISTINCTIVE DRAFTING & DESIGN HEREBY RESERVES ITS COMMON COPYRIGHT LAW & OTHER PROPERTY RIGHTS IN THESE PLANS & DESIGNS. THESE PLANS ARE NOT TO BE REPRODUCED, CHANGED OR COPIED IN ANY FORM OR MANNER WHATSOEVER, NOR ARE THEY TO BE ASSIGNED TO ANY THIRD PARTY, WITHOUT FIRST OBTAINING THE EXPRESS WRITTEN PERMISSION FROM DISTINCTIVE DRAFTING & DESIGN. DISTINCTIVE DRAFTING & DESIGN TAKES NO RESPONSIBILITY FOR THE CONSTRUCTION OF THE RESIDENCE OR BUILDING.

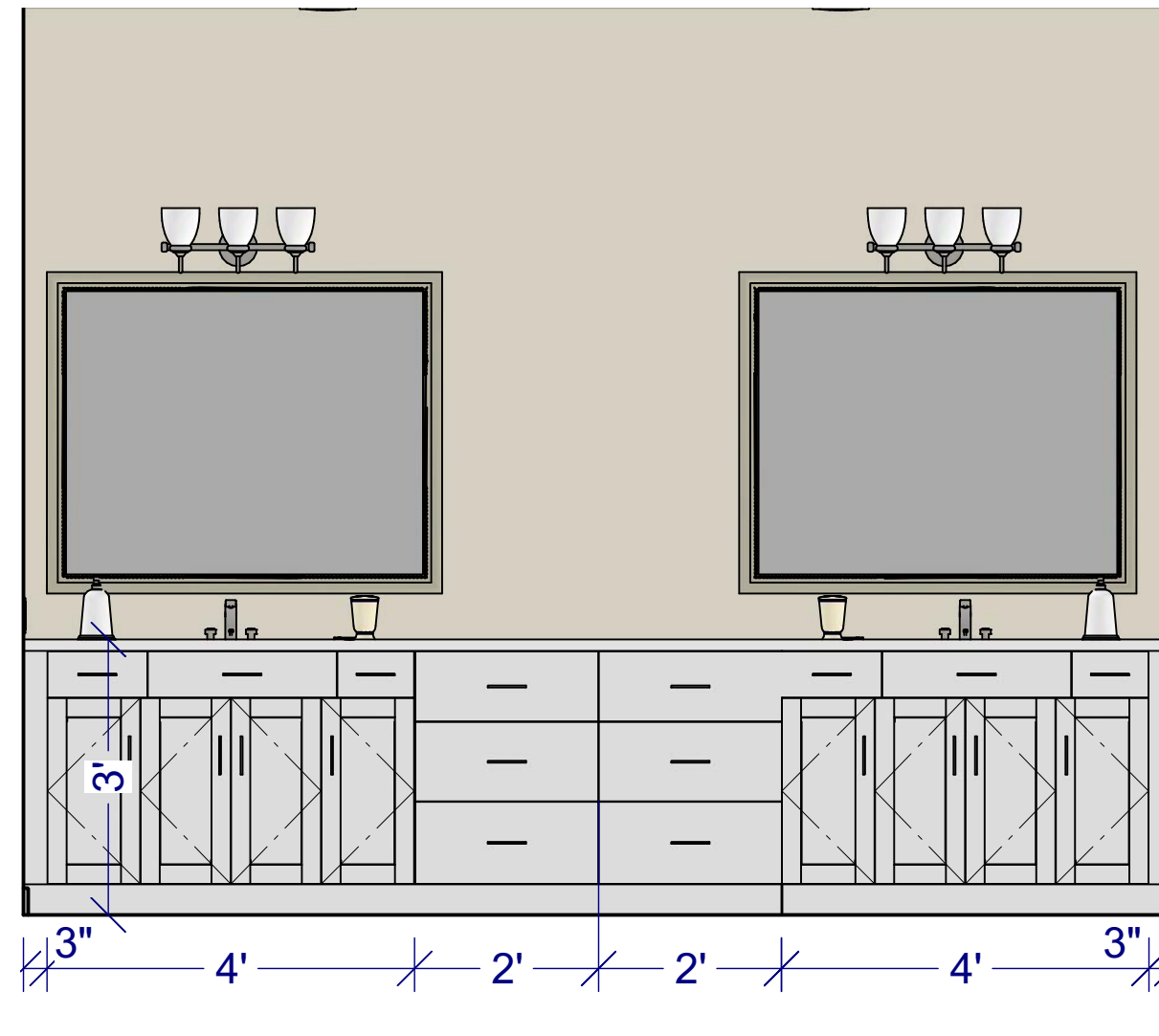

**MASTER BATH
ELEVATION**
SCALE: 1/2"=1'-0"

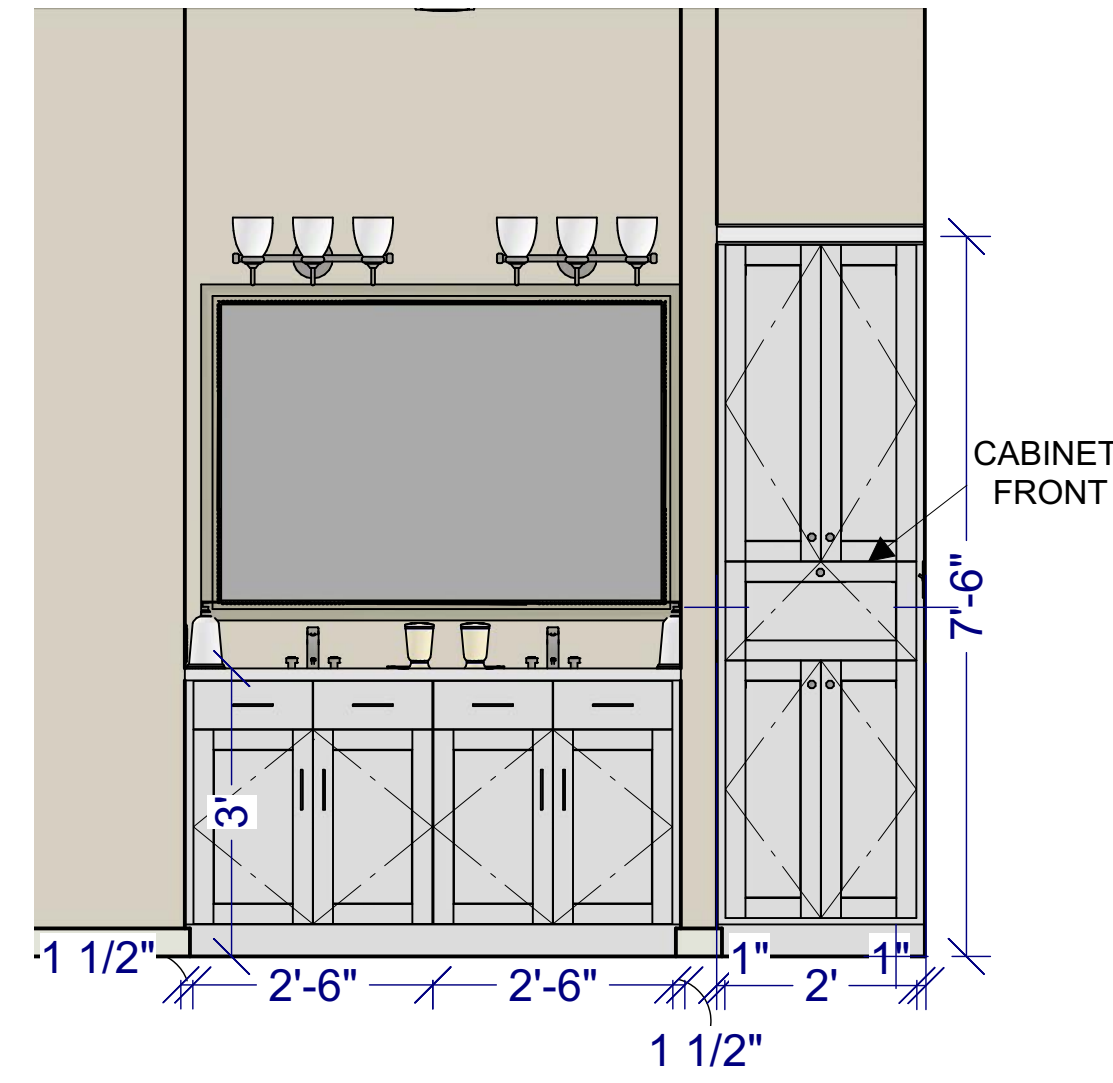

**BATH #2, #3
ELEVATION**
SCALE: 1/2"=1'-0"

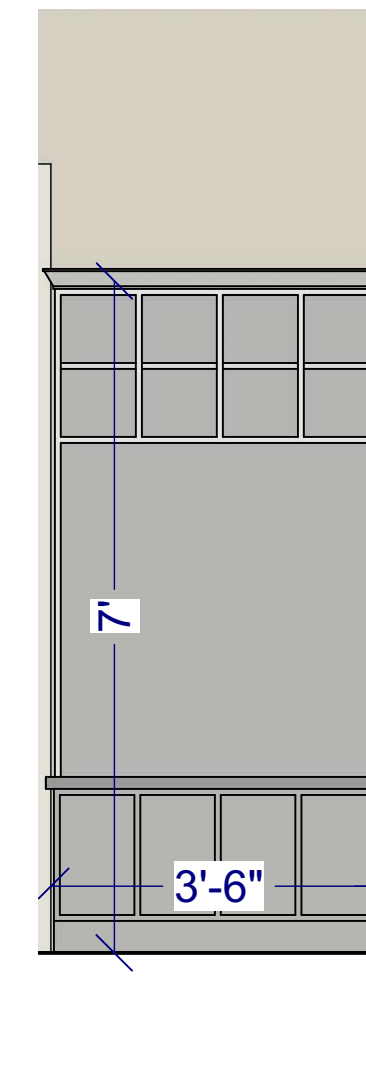

**MUD
ELEVATION**
SCALE: 1/2"=1'-0"

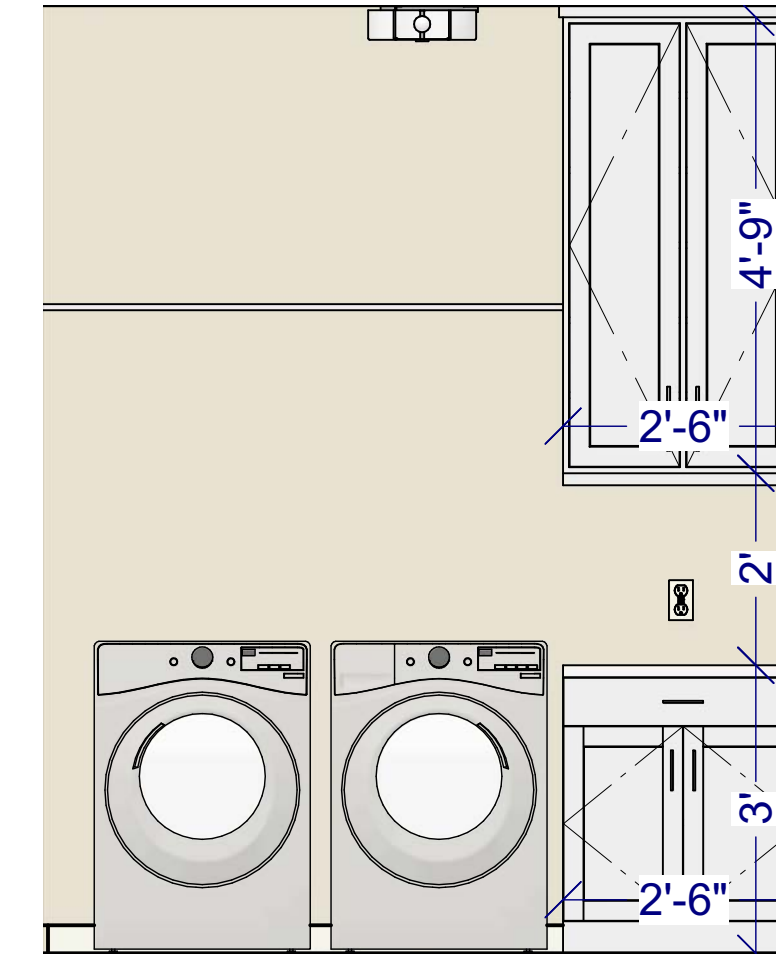

**UTILITY
ELEVATION**
SCALE: 1/2"=1'-0"

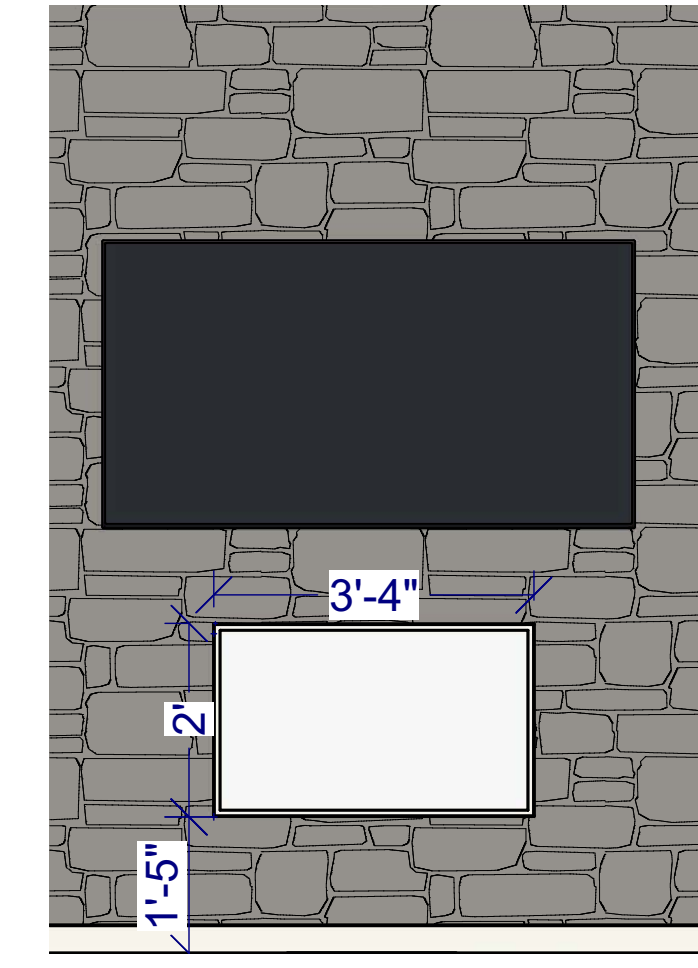

**LIVING
ELEVATION**
SCALE: 1/2"=1'-0"

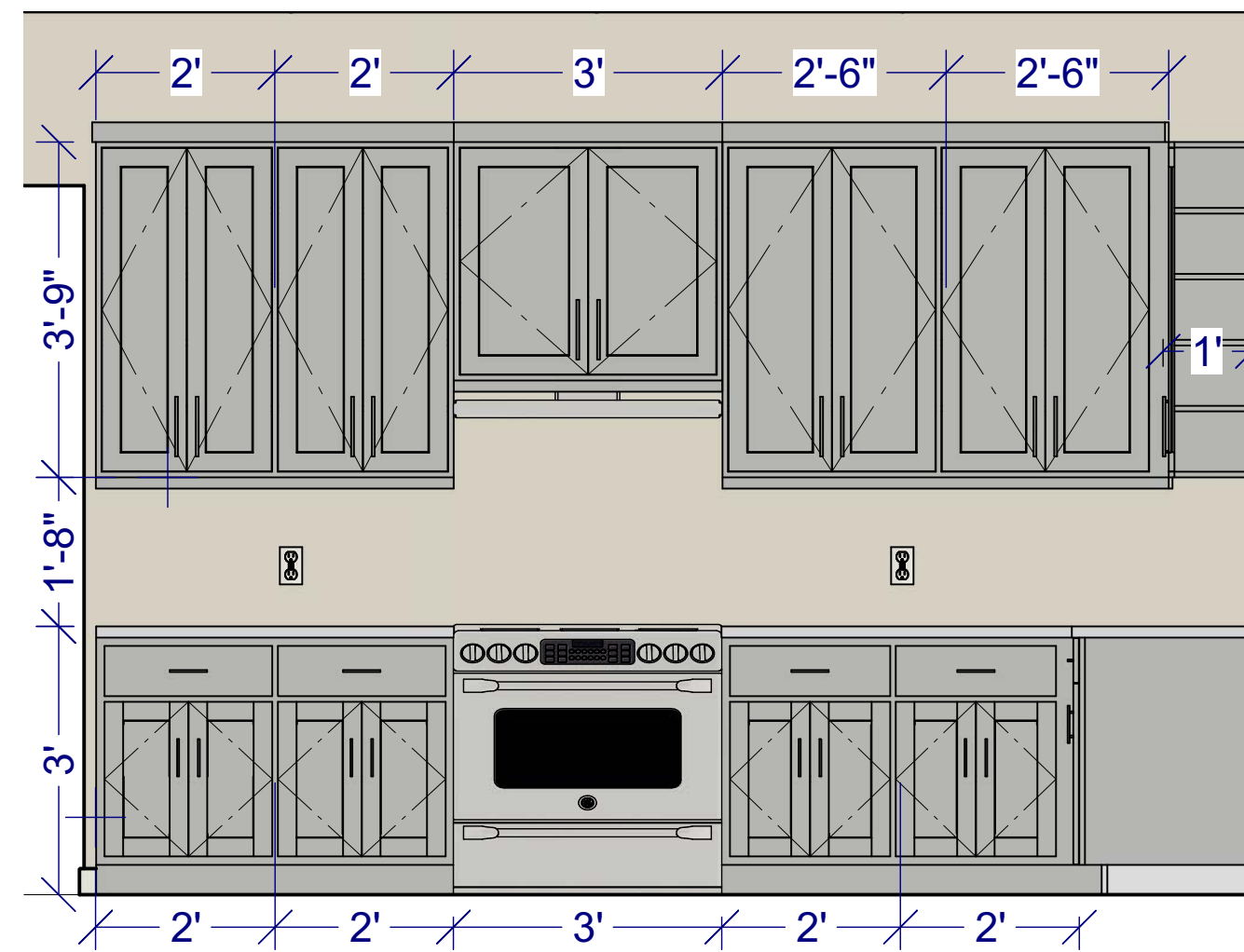

**KITCHEN
ELEVATION**
SCALE: 1/2"=1'-0"

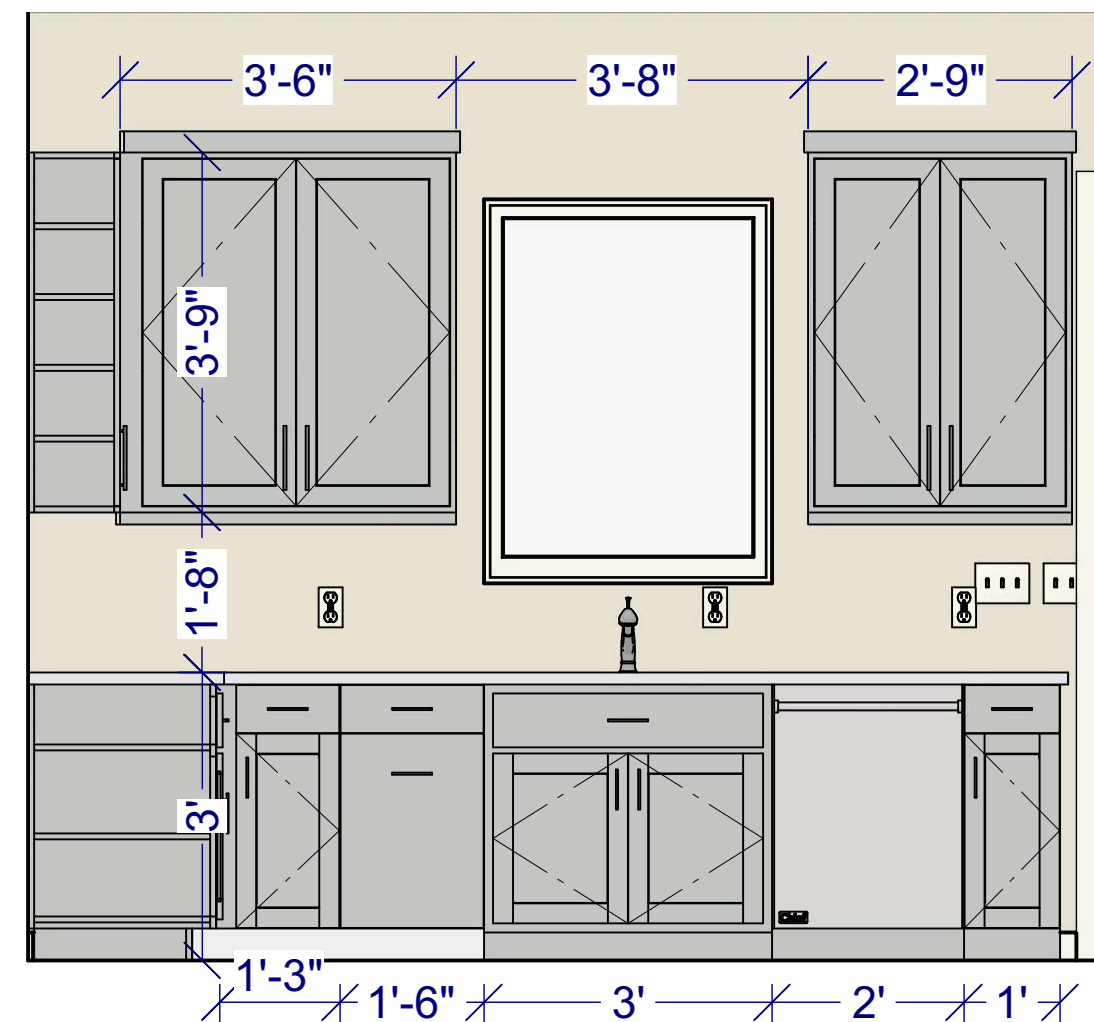

**KITCHEN
ELEVATION**
SCALE: 1/2"=1'-0"

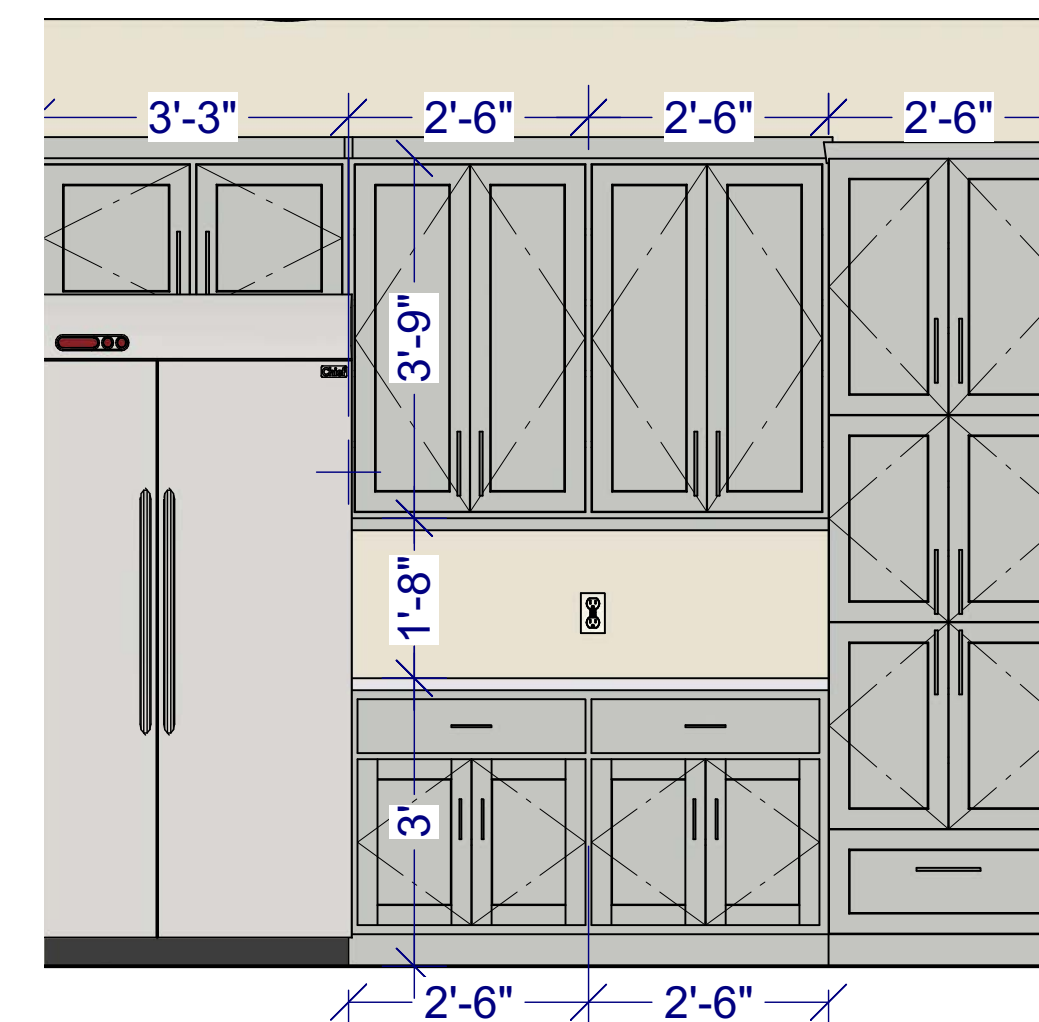

**KITCHEN
ELEVATION**
SCALE: 1/2"=1'-0"

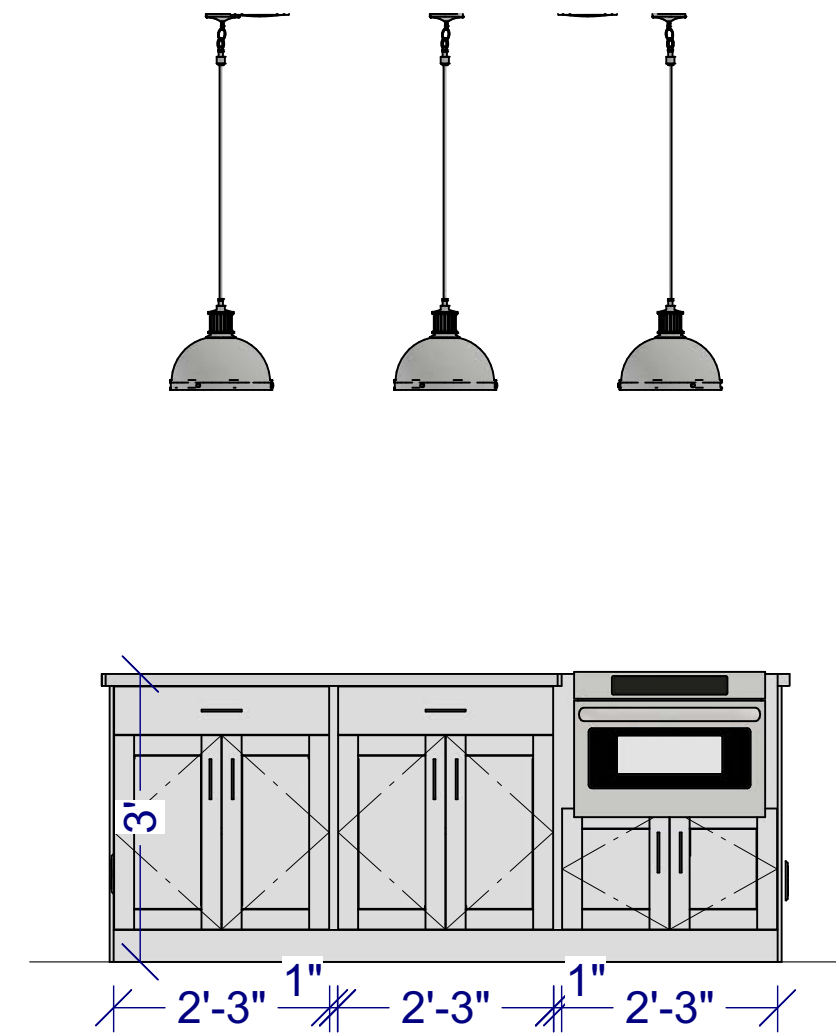

KITCHEN ISLAND
SCALE: 1/2"=1'-0"

PRICING SET

DISTINCTIVE DRAFTING & DESIGN HEREBY RESERVES ITS COMMON COPYRIGHT LAW & OTHER PROPERTY RIGHTS IN THESE PLANS & DESIGNS. THESE PLANS ARE NOT TO BE REPRODUCED, CHANGED OR COPIED IN ANY FORM OR MANNER WHATSOEVER, NOR ARE THEY TO BE ASSIGNED TO ANY THIRD PARTY, WITHOUT FIRST OBTAINING THE EXPRESS WRITTEN PERMISSION FROM DISTINCTIVE DRAFTING & DESIGN. DISTINCTIVE DRAFTING & DESIGN TAKES NO RESPONSIBILITY FOR THE CONSTRUCTION OF THE RESIDENCE OR BUILDING.

DATE: 1/27/2022
DRAWN BY:
DISTINCTIVE
PLAN # - 13-21

**Lot 160, Cascada at
Canyon Lake Unit 3,
Comal County
118 Cartama**



2312 S. EXPRESSWAY 83 SUITE # B
HARLINGEN, TX 78552
OFFICE: (956) 425-7040
8000 WEST I-10 SUITE #600
SAN ANTONIO, TX 78230
OFFICE: (210) 525-7985

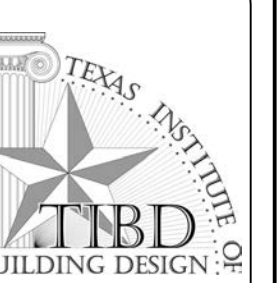

SHEET NUMBER

12

© 2021